

Chapter 79

OIL

FBA-2C1, FBA-2C2, FBA-2C3
FBA-2C4, FBA-2C3T, FBA-2C4T

Found Aircraft Canada
Maintenance Program FAC2-M200

INTENTIONALLY LEFT BLANK

LIST OF EFFECTIVE PAGES			
Chapter	Section	Page No.	Date
79	79-Title	1	January 23, 2012
		2	January 23, 2012
	79-LOEP	1	January 23, 2012
		2	January 23, 2012
	79-TOC	1	January 23, 2012
		2	January 23, 2012
	79-00	1	July 28, 2008
		2	July 28, 2008
	79-20	1	July 28, 2008
		2	July 28, 2008
		3	July 28, 2008
		4	July 28, 2008
	79-31	1	July 28, 2008
		2	July 28, 2008
	79-33	1	July 28, 2008
		2	July 28, 2008

FBA-2C1, FBA-2C2, FBA-2C3
FBA-2C4, FBA-2C3T, FBA-2C4T

Found Aircraft Canada
Maintenance Program FAC2-M200

INTENTIONALLY LEFT BLANK

FBA-2C1, FBA-2C2, FBA-2C3
FBA-2C4, FBA-2C3T, FBA-2C4T

Found Aircraft Canada
Maintenance Program FAC2-M200

INTENTIONALLY LEFT BLANK

79 OIL

79-00 GENERAL

The engine has a wet sump with a capacity of 12 US quarts (IO-540) or 11 US quarts (IO-580). There is a full flow oil filter mounted on the accessory section of the engine. A plug in the engine sump allows the oil to be drained. A dipstick allows for the oil level to be checked. There are also sensors for oil temperature and oil pressure.

When ever an oil system component is changed the engine should be run to check for oil leaks.

To change oil and replace oil filter, see Chapter 12-10-21 and 12-10-22.

FBA-2C1, FBA-2C2, FBA-2C3
FBA-2C4, FBA-2C3T, FBA-2C4T

Found Aircraft Canada
Maintenance Program FAC2-M200

INTENTIONALLY LEFT BLANK

79-20 OIL COOLER

The oil cooler is mounted on the left hand side of the firewall in the engine compartment. The outside air enters the engine compartment and it travels through duct/diffuser directly attached to the oil cooler, see Figure 79-20-01 for 2C1 & 2C2 aircraft, and Figure 79-20-02 for 2C3 & 2C4 aircraft.

Oil Cooler Removal

Refer to Figure 79-20-01 for 2C1 & 2C2 and Figure 79-20-02 for 2C3 & 2C4 aircraft.

- Step 1. Gain access to the oil cooler. 2C1 & 2C2 aircraft - through engine access CP1. 2C3 & 2C4 aircraft – remove left hand (port) cowl per 71-10.
- Step 2. Remove the oil cooler inlet and outlet lines at the engine. Cap oil cooler lines and engine fittings.
- Step 3. Remove hardware securing the diffuser to the oil cooler (6 places).
- Step 4. Remove hardware securing the oil cooler to support brackets (6 places).
- Step 5. Oil cooler is now free.

Oil Cooler Installation

Before the oil cooler is to be installed it must be purged of air to ensure maximum efficiency. Place the oil cooler, complete with inlet and outlet lines flat on bench. Slowly fill the oil cooler inlet line with oil. Wait about five minutes and fill the line again. Repeat the process until the oil level in the line no longer goes down. Raise the inlet/outlet end of the oil cooler about 45° and let stand about five minutes. If oil level in line is observed to go down -refill while still at 45°. Oil cooler is now ready for installation.

- Step 1. Place oil cooler on oil cooler attachment brackets and install six bolts.
- Step 2. Attach oil inlet and oil outlet lines to engine fittings.
- Step 3. Install hardware securing the oil cooler to the diffuser (6 places).
- Step 4. Check engine oil quantity. Replenish if necessary.
- Step 5. Carry out engine run. Inspect oil cooler installation for leaks.
- Step 6. Check engine oil quantity. Replenish if necessary.

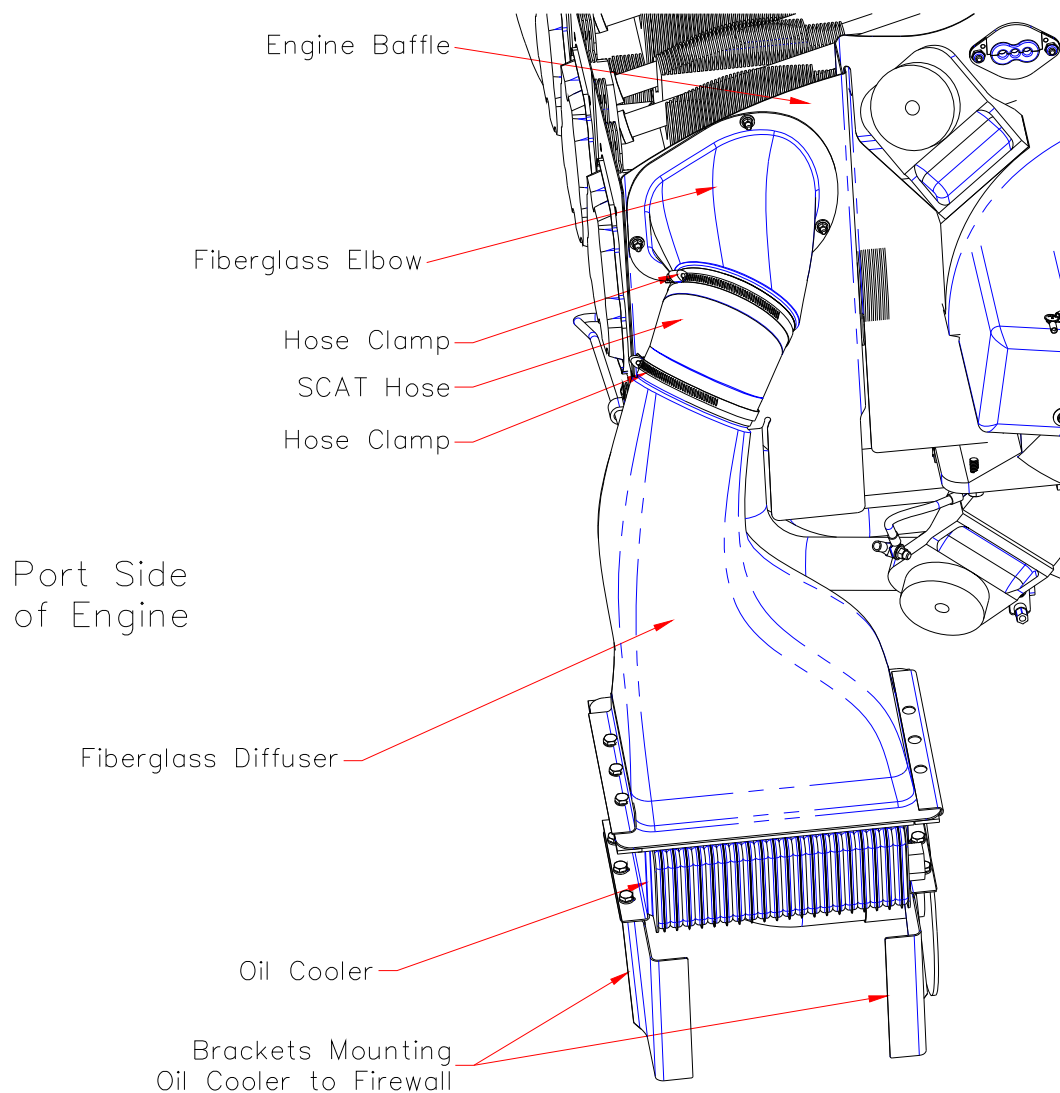

Figure 79-20-01 Oil Cooler Installation (2C1 & 2C2)

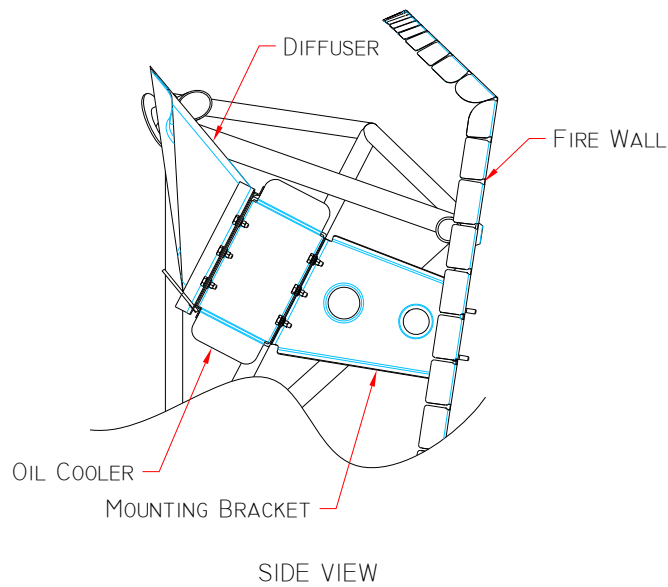
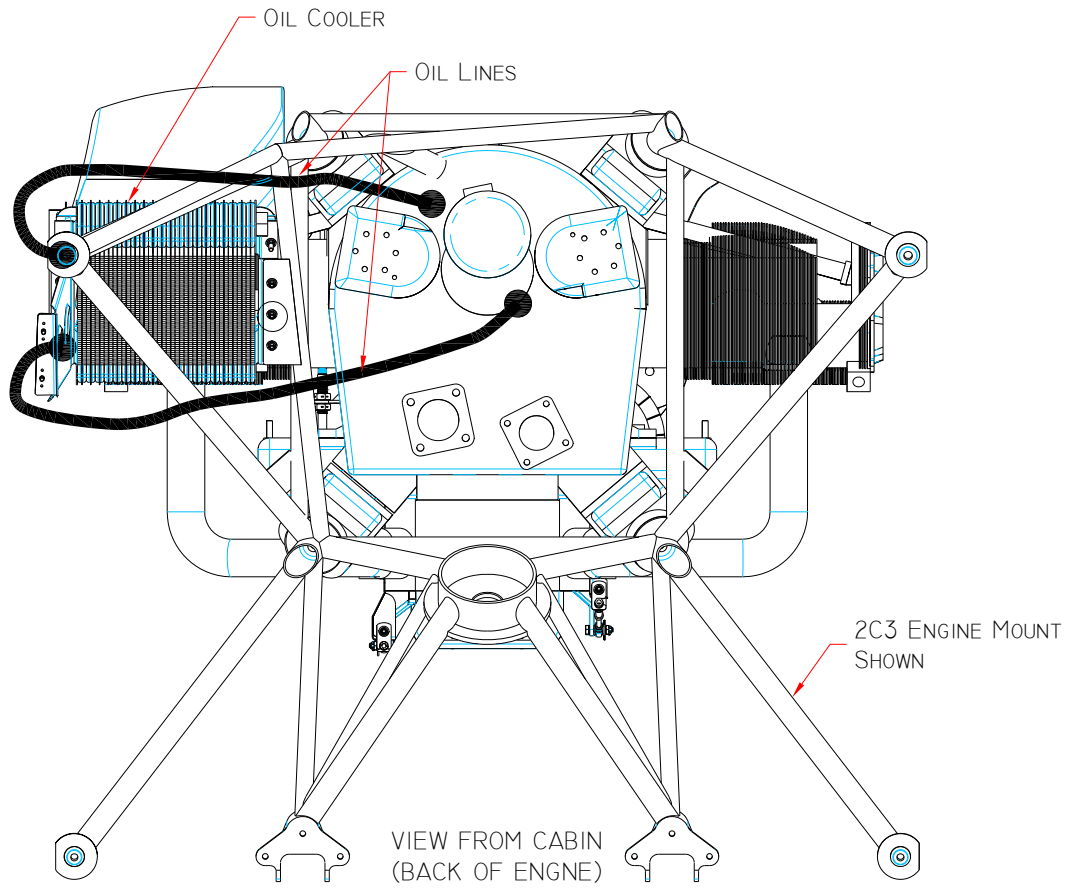

Figure 79-20-02 Oil Cooler Installation (2C3 & 2C4)

FBA-2C1, FBA-2C2, FBA-2C3
FBA-2C4, FBA-2C3T, FBA-2C4T

Found Aircraft Canada
Maintenance Program FAC2-M200

INTENTIONALLY LEFT BLANK

79-31 ENGINE OIL PRESSURE

In the 2C1 & 2C2 aircraft, the oil pressure gauge is located in the instrument cluster. For electrical description, removal and installation instructions refer to Chapter 77-40.

In the 2C3 & 2C4 aircraft, the oil pressure is displayed by the MVP-50.

79-31-01 Oil Pressure Sensor/Transmitter (2C1 & 2C2)

The oil pressure sensor/transmitter is located on the forward face of the firewall, to the right of center, about 3 ¼" from the top.

Sensor/Transmitter Removal

- Step 1. Gain access to the Sensor/Transmitter through engine access CS1.
- Step 2. Remove the two oil lines from the Sensor/Transmitter. Cap lines and fittings.
- Step 3. Remove the four screws which attach the Sensor/Transmitter to the firewall.

Sensor/Transmitter Installation

- Step 1. Locate the Sensor/Transmitter on the firewall and install the four screws.
- Step 2. Attach the two oil lines to the Sensor/Transmitter.
- Step 3. Carry out an engine run to confirm oil pressure Sensor/Transmitter operation.
- Step 4. Inspect oil pressure Sensor/Transmitter installation for evidence of oil leaks.

79-31-02 Oil Pressure Sensor/Transmitter (2C3 & 2C4)

The oil pressure sensor/transmitter is located on the upper tube of the engine mount on the starboard side.

Refer to Figure 79-31-01

Sensor/Transmitter Removal

- Step 1. Remove right hand (starboard) cowl per 71-10
- Step 2. Disconnect the oil line. Cap the line and fitting.

Step 3. Disconnect wires.

Step 4. Remove the hardware securing the two clamps to the sensor.

Step 5. The oil sensor/transmitter is now free.

Sensor/Transmitter Installation

Step 1. Place two clamps on the sensor.

Step 2. Place in position and install hardware (2 places)

Step 3. Connect wires.

Step 4. Connect oil line.

Step 5. Carry out an engine run to confirm oil pressure Sensor/Transmitter operation.

Step 6. Inspect oil pressure Sensor/Transmitter installation for evidence of oil leaks.

Step 7. Install cowl per 71-10.

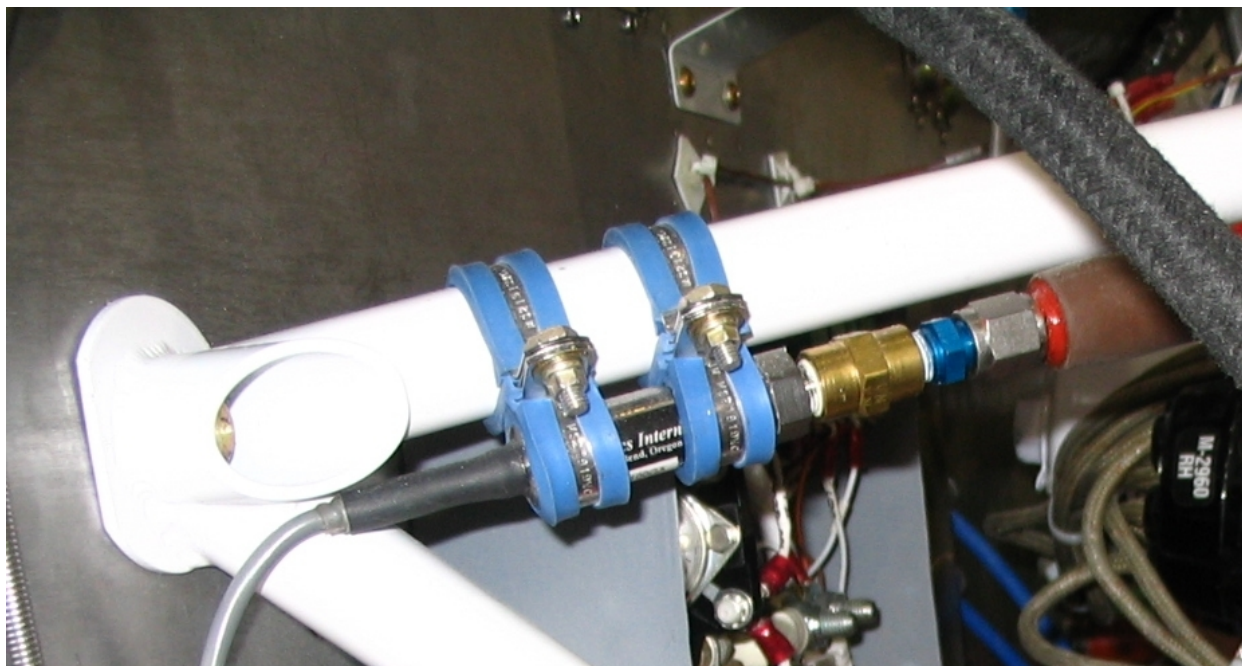

Figure 79-31-01 Oil Pressure Sensor Installation (2C3 & 2C4)

79-33 ENGINE OIL TEMPERATURE

In the 2C1 & 2C2 aircraft, the oil temperature gauge is located in the instrument cluster. For electrical description, removal and installation instructions refer to Chapter 77-40.

In the 2C3 & 2C4 aircraft, the oil pressure is displayed by the MVP-50 Engine Monitor.

79-33-01 Oil Temperature Transmitter

The oil temperature transmitter is located at the rear of the engine on the accessory drive section, just forward of the oil filter.

Refer to Figure 79-33-01

Temperature Transmitter Removal

- Step 1. Gain access to the temperature transmitter. 2C1 & 2C2 aircraft use engine access CP1. 2C3 & 2C4 aircraft remove port cowl per 71-10.
- Step 2. Locate the oil temperature probe and remove the lock wire securing transducer
- Step 3. Disconnect cannon plug (2C1 & 2C2).
- Step 4. Remove the Transmitter from the accessory drive section. Plug the opening. Scrap the crush washer and replace with new on installation.

Sensor/Transmitter Installation

- Step 1. Install the temperature transmitter in the accessory drive section. Use a new crush washer.
- Step 2. Torque transmitter per applicable Lycoming manual.
- Step 3. Attach the cannon plug to the transmitter (2C1 & 2C2).
- Step 4. Lock wire.
- Step 5. Carry out an engine run to confirm oil temperature transmitter operation.
- Step 6. Inspect oil temperature transmitter installation for evidence of oil leaks.

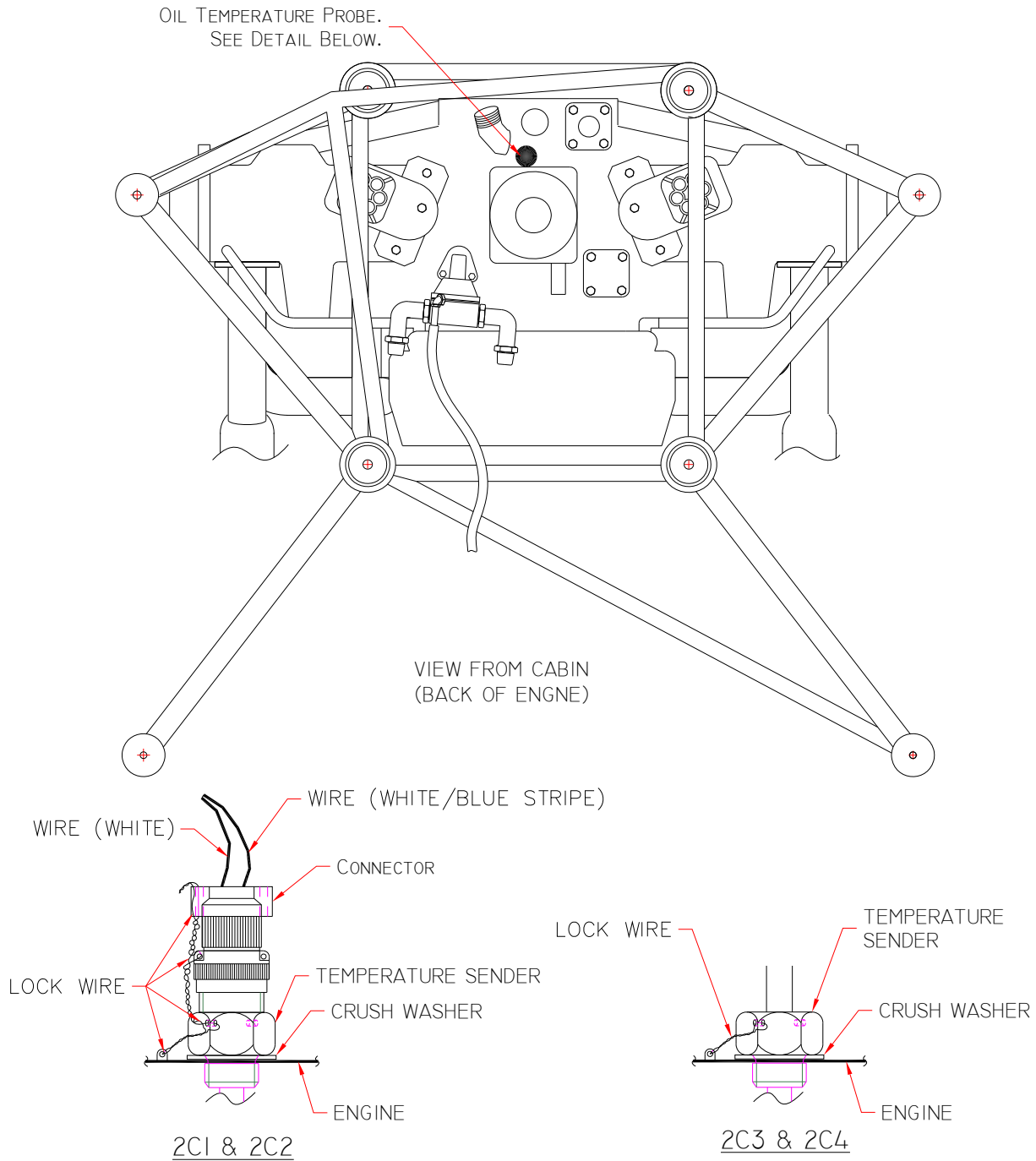

Figure 79-33-01 Oil Temperature Transmitter Installation